

TOP MULTI

Submersible multi-stage pumps

 Clean water

 Domestic use

 Civil use



TOP MULTI 1



TOP MULTI 2
TOP MULTI 3

PERFORMANCE RANGE

- Flow rate up to **120 l/min** (7.2 m³/h)
- Head up to **42 m**

APPLICATION LIMITS

- Immersion depth:
 - up to **3 m** for TOP MULTI 1
 - up to **10 m** for TOP MULTI 2-3 (with a sufficiently long power cable)
- Maximum liquid temperature **+40 °C**
- Suction level:
 - **25 mm** above ground level for TOP MULTI 1
 - **35 mm** above ground level for TOP MULTI 2-3
- Continuous service **S1**

CONSTRUCTION AND SAFETY STANDARDS

Complete with:

- **10 m** long power cable
- float switch
- hose connector Ø 35 mm
- complete connector with flap-check valve

EN 60335-1
IEC 60335-1
CEI 61-150

EN 60034-1
IEC 60034-1
CEI 2-3



CERTIFICATIONS

Company with management system certified DNV
ISO 9001: QUALITY



INSTALLATION AND USE

TOP MULTI® pumps are recommended for pumping **clean water** and liquids that are not chemically aggressive for the materials from which the pump is made.

Because of their high efficiency and reliability they are suitable for use in applications such as domestic water supply from reservoirs, tanks or relatively deep wells, for drawing rain water from cisterns to water gardens or for use in irrigation systems, etc.

PATENTS - TRADE MARKS - MODELS

- Registered EU Design n. 000885587 for TOP MULTI 2-3
- TOP MULTI® Registered Trade Mark n. 0001334477

OPTIONS AVAILABLE ON REQUEST

- Pumps without float switch
- Other voltages or 60 Hz frequency

CHARACTERISTIC CURVES AND PERFORMANCE DATA

50 Hz n= 2900 min⁻¹

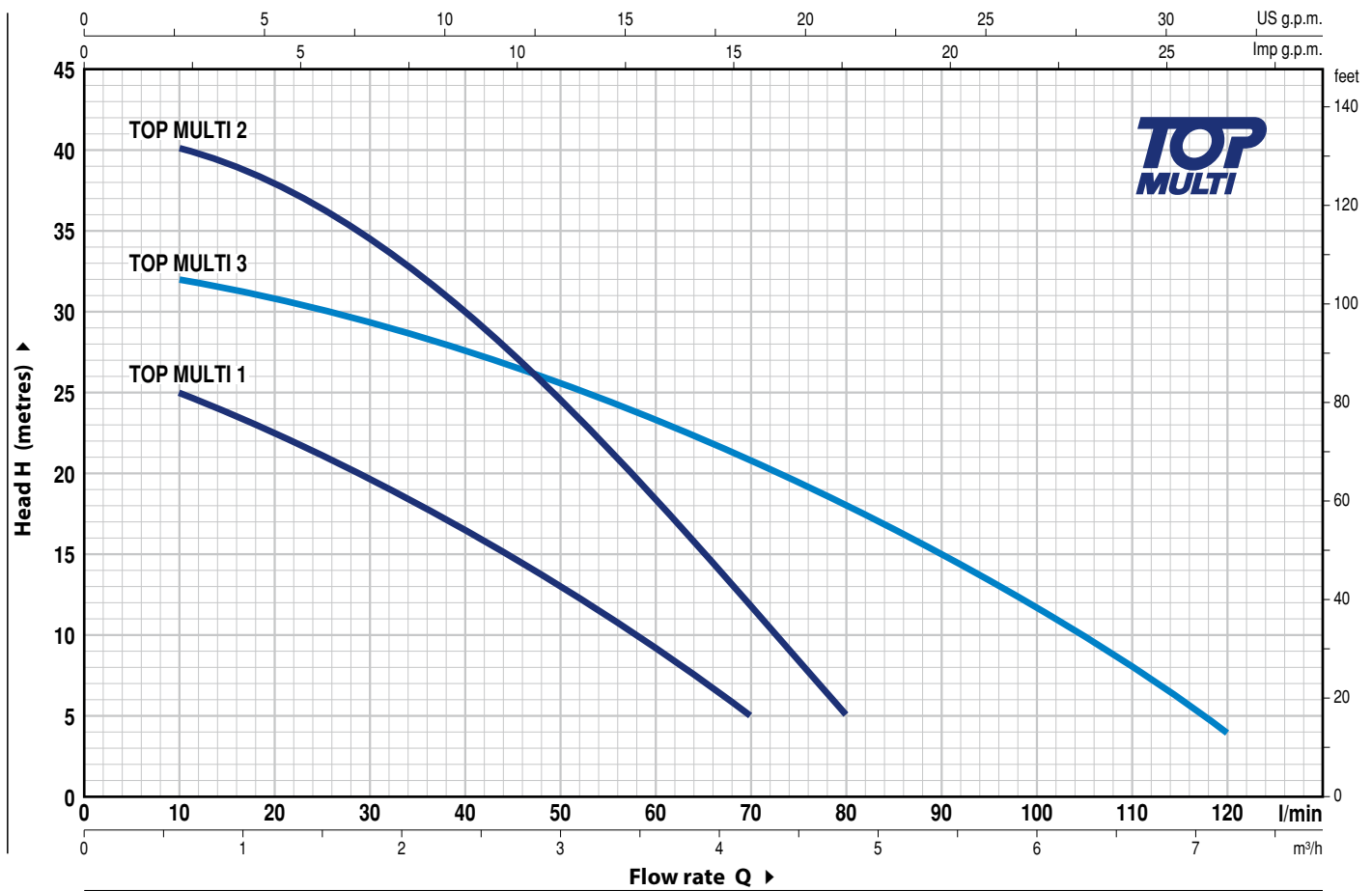

MODEL Single-phase	POWER (P ₂)		Q	0	0.6	1.2	1.8	2.4	3.0	3.6	4.2	4.8	5.4	6.0	6.6	7.2
	kW	HP		0	10	20	30	40	50	60	70	80	90	100	110	120
TOP MULTI 1	0.37	0.50	H metres	27	25	22.5	19.5	16.5	13	9	5					
TOP MULTI 2	0.55	0.75		42	40	38	34	30	24	18	11.5	5				
TOP MULTI 3	0.55	0.75		33	32	31	29.5	28	25.5	23	20.5	18	15	12	8	4

Q = Flow rate H = Total manometric head

Tolerance of characteristic curves in compliance with EN ISO 9906 Grade 3B.

TOP MULTI 1

POS. COMPONENT

CONSTRUCTION CHARACTERISTICS

1	PUMP BODY	Glass fibre reinforced technopolymer complete with threaded delivery port in compliance with ISO 228/1
2	SUCTION FILTER	Glass fibre reinforced technopolymer
3	STAGE CASING	Glass fibre reinforced technopolymer
4	IMPELLERS	Noryl FE1520PW
5	DIFFUSER AND STAGE BOXES	Noryl FE1520PW complete with anti-wear ring
6	VANE DIFFUSER	Glass fibre reinforced technopolymer
7	MOTOR CASING	Stainless steel AISI 304
8	MOTOR CASING PLATE	Stainless steel AISI 304
9	MOTOR SHAFT	Stainless steel AISI 431

10 SHAFT WITH DOUBLE SEAL AND OIL CHAMBER

Seal Model	Shaft Diameter	Materials			
		Stationary ring	Rotational ring	Elastomer	Metals
STA-12R	Ø 12 mm	Ceramic	Graphite	NBR	AISI 304

11 **LIP SEAL** **Ø 12 x Ø 19 x H 5 mm**

12 **BEARINGS** **6201 ZZ - C3E / 6201 ZZ - C3E**

13 CAPACITOR

Capacitance (230 V or 240 V)	(110 V)
10 µF 450 VL	16 µF 250 VL

14 ELECTRIC MOTOR

TOP MULTI 1: single-phase 230 V - 50 Hz with thermal overload protector incorporated into the winding.

- Insulation: class F
- Protection: IP X8

15 HANDLE ASSEMBLY (resin sealed)

- Complete with:
- **10 metres** long "H07 RN-F" power cable with Schuko plug
 - Float switch

16 HOSE CONNECTOR WITH RING NUT

Ø 35 mm hose connection

PIPE COUPLING

Threaded 1¼" in compliance with ISO 228/1, complete with flap-check valve

(Included in the equipment)

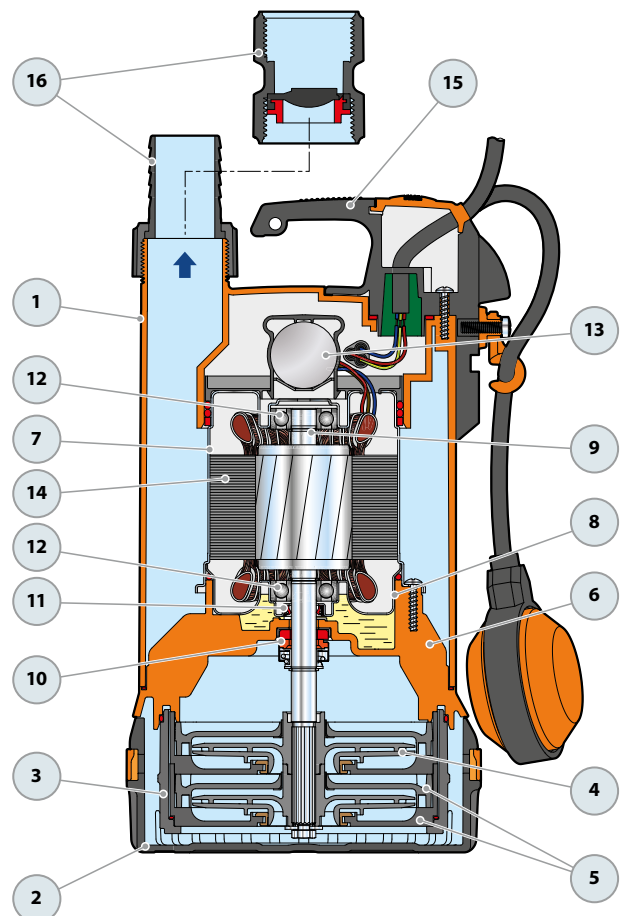

DIMENSIONS AND WEIGHT

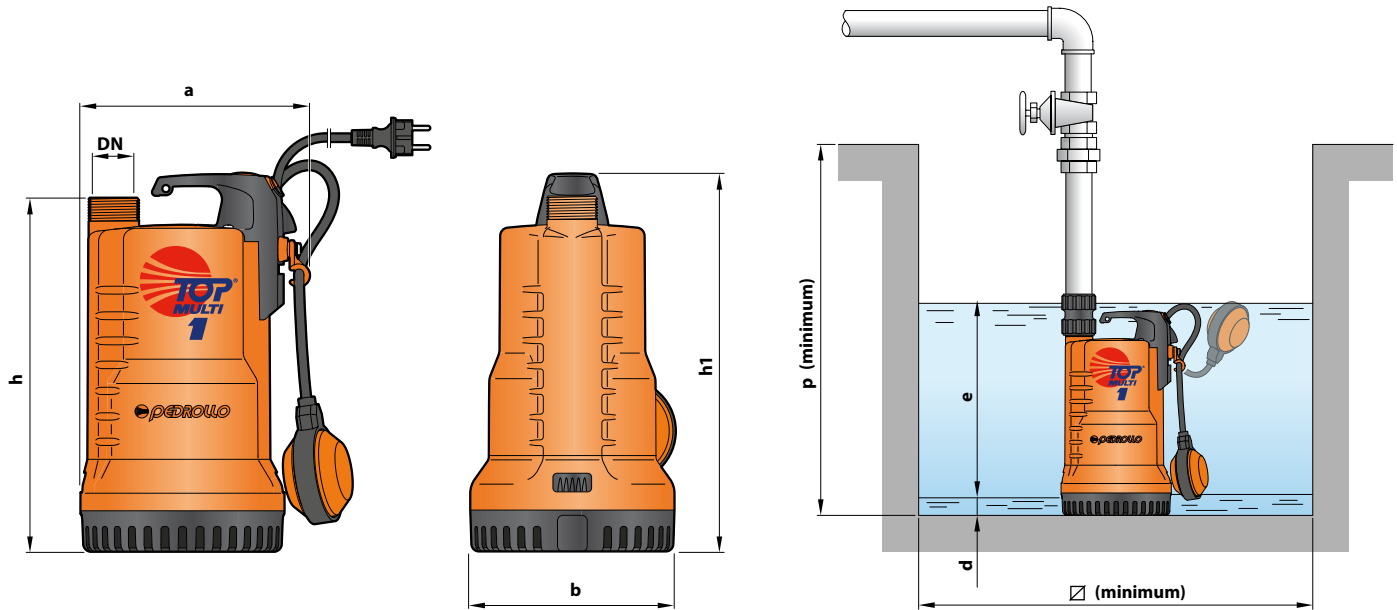

MODEL	PORT DN	N. STAGES	DIMENSIONS mm								kg	
			a	b	h	h1	d	e	p	∅		
Single-phase	DN											
TOP MULTI 1	1¼"	2	192	170	295	315	25	variable	350	350	6.8	

ABSORPTION

MODEL	VOLTAGE		
	Single-phase	230 V	240 V
TOP MULTI 1	2.0 A	2.0 A	4.0 A

PALLETIZATION

MODEL	GROUPAGE	CONTAINER
Single-phase	n. pumps	n. pumps
TOP MULTI 1	60	100

TOP MULTI 2-3

POS. COMPONENT CONSTRUCTION CHARACTERISTICS

1	DELIVERY BODY	Glass fibre reinforced technopolymer complete with threaded delivery port in compliance with ISO 228/1
2	PUMP BODY AND SUCTION FILTER	Glass fibre reinforced technopolymer
3	DIFFUSER	Glass fibre reinforced technopolymer
4	MOTOR SLEEVE AND MOTOR CASING PLATE	Stainless steel AISI 304
5	IMPELLERS	Noryl FE1520PW
6	DIFFUSERS	Noryl complete with anti-wear ring
7	MOTOR SHAFT	Stainless steel AISI 431

8 TWO MECHANICAL SEALS SEPARATED BY AN OIL CHAMBER

Seal Model	Shaft Diameter	Position	Materials		
			Stationary ring	Rotational ring	Elastomer
STA-13R	Ø 13 mm	Motor side	Ceramic	Graphite	NBR
STA-12R SG	Ø 12 mm	Pump side	Silicon carbide	Graphite	NBR

9 BEARINGS 6202 ZZ - C3 / 6201 ZZ

10 CAPACITOR

Capacitance

(230 V or 240 V)	(110 V)
12.5 µF 450 VL	30 µF 250 VL

11 ELECTRIC MOTOR

TOP MULTI: single-phase 230 V - 50 Hz with thermal overload protector incorporated into the winding.

- Insulation: class F
- Protection: IP X8

12 POWER CABLE

"H07 RN-F" with Schuko plug

Standard length 10 metres

13 FLOAT SWITCH

14 HOSE CONNECTOR WITH RING NUT

Ø 35 mm hose connection

PIPE COUPLING

Threaded 1¼" in compliance with ISO 228/1, complete with flap-check valve

(Included in the equipment)

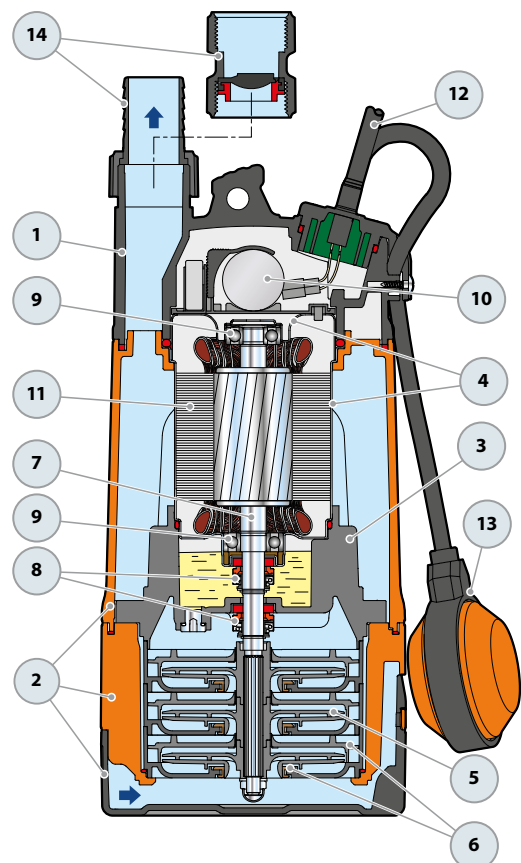

DIMENSIONS AND WEIGHT

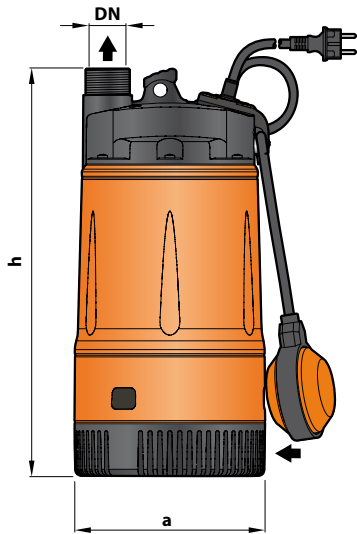

Standard installation



MODEL	PORT	N. STAGES	DIMENSIONS mm		kg
			a	h	
Single-phase	DN				
TOP MULTI 2	1 1/4"	3	178	380	9.2
TOP MULTI 3					9.3

ABSORPTION

MODEL	VOLTAGE		
	Single-phase	230 V	240 V
TOP MULTI 2	3.4 A	3.3 A	6.6 A
TOP MULTI 3	3.6 A	3.5 A	7.2 A

PALLETIZATION

MODEL	GROUPAGE	CONTAINER
Single-phase	n. pumps	n. pumps
TOP MULTI 2	60	80
TOP MULTI 3	60	80

