



## Assembly and Installation Instructions

### Electric Heat Exchanger of the Series D-EWT C / Evo / Ti / Neo / E

If you do not pay proper attention to these installation instructions the manufacturer cannot accept liability for any resulting damage to the device itself, the environment, property, or personal injury.

#### Your safety is our concern!

These Electric Heat Exchangers consist of a stainless steel, titanium or plastic casing and a built-in heating element, made out of Incoloy 825, or a titanium casing and a built-in electric heating element, made out of full titanium.

#### 1. Purpose:

These Electric Heat Exchangers are made to heat up bathing water in swimming pools and whirlpools while the pump is running. It is not permitted to change and/or modify the device without consulting the manufacturer.

#### 2. Safety Warning:

- 2.1 This device has not been designed for use by individuals (including children) with physical, mental or sensory disabilities, or people who lack the necessary experience and/or knowledge unless under the supervision of someone entrusted with their safety or instructed by that person in how the device should be used.
- 2.2 Attention: never open the control box without disconnecting it carefully from the electrical power supply and to be secured against unintentional switching on!

#### 3. Important:

- 3.1 Anybody involved with the installation, start-up, use, maintenance, and/or repair of the Electric Heat Exchanger must be qualified and carefully follow the instructions.
- 3.2 Only a specialized electrical technician (VDE 0105) may operate the device following the DIN VDE 0100 safety standards.

#### 4. Fire Hazard:

Improper handling or failure of the safety device can lead to overheating. In extreme cases the Electric Heat Exchanger could reach temperatures up to °C 100.

- 4.1 Do not install the device near flammable material.
- 4.2 If the unit is mounted to the wall, especially if the construction material is easily flammable, a heat resistant plate must be inserted between the Electric Heat Exchanger and the wall. That plate should be at least 10 cm longer and wider than the Electric Heat Exchanger.
- 4.3 Do not use covers or insulation.
- 4.4 The sensor of the safety thermostat must be inserted into the thermowell before the sensor of the control thermostat.

#### 5. Safety Devices:

- 5.1 The Electric Heat Exchanger should be protected by three safety switches.
- 5.2 Unless the client asks for less, the Electric Heat Exchanger is standardly equipped with the following safety features:
  - a) Control thermostat 0°C to 40°C
  - b) Safety thermostat up to 50°C
  - c) Flow control \* ' \*\* or pressure switch \*\*\*

**Don't control the device with the flow switch/ pressure switch but through the filter pump; see 11.8 and circuit layout**

- 5.3 If the limit is exceeded, the safety device will switch off the Electric Heat Exchanger.

#### 6. Corrosion Prevention:

- 6.1 The Electric Heat Exchanger should be mounted in a dry place. Dripping water containing iron could damage the stainless steel casing.
- 6.2 Be careful not to wash any metals into the Electric Heat Exchanger when connecting it to the water circuit.
- 6.3 The Electric Heat Exchanger must be mounted so it can always be completely full of water or completely empty. During off season it can also be completely drained.



6.4 To avoid corrosion make sure not to exceed the following water parameters:

**AISI:** Chloride content: max. 500 mg/l  
Free Chlorine: max. 1 mg/l  
PH: max. 6,8 – 7,8

**Ti:** Chloride content: max. 3000 mg/l  
Free Chlorine: no limit  
PH: max. 6,8 – 7,8  
Salt: max. 3%

Be careful: The disinfection device should be installed after the Electric Heat Exchanger in a way so that neither chemicals, nor gases can enter it while it is switched off.

**7. Frost:**

During frost the Electric Heat Exchanger needs to be completely empty. The flow monitor has to be dismantled and stored in a frost-proof place.

**8. Please Note:**

The specific water resistance at 15°C may not be below 550 kg OHM x cm. When the limits are properly taken into consideration (see above), the water resistance will remain between 1,5 Mega OHM x cm and 550 Kilo OHM x cm.

**9. Operating Pressure:**

Do not exceed the 3 bar \* ' \*\*\* or 2,5 bar \*\* operating system.

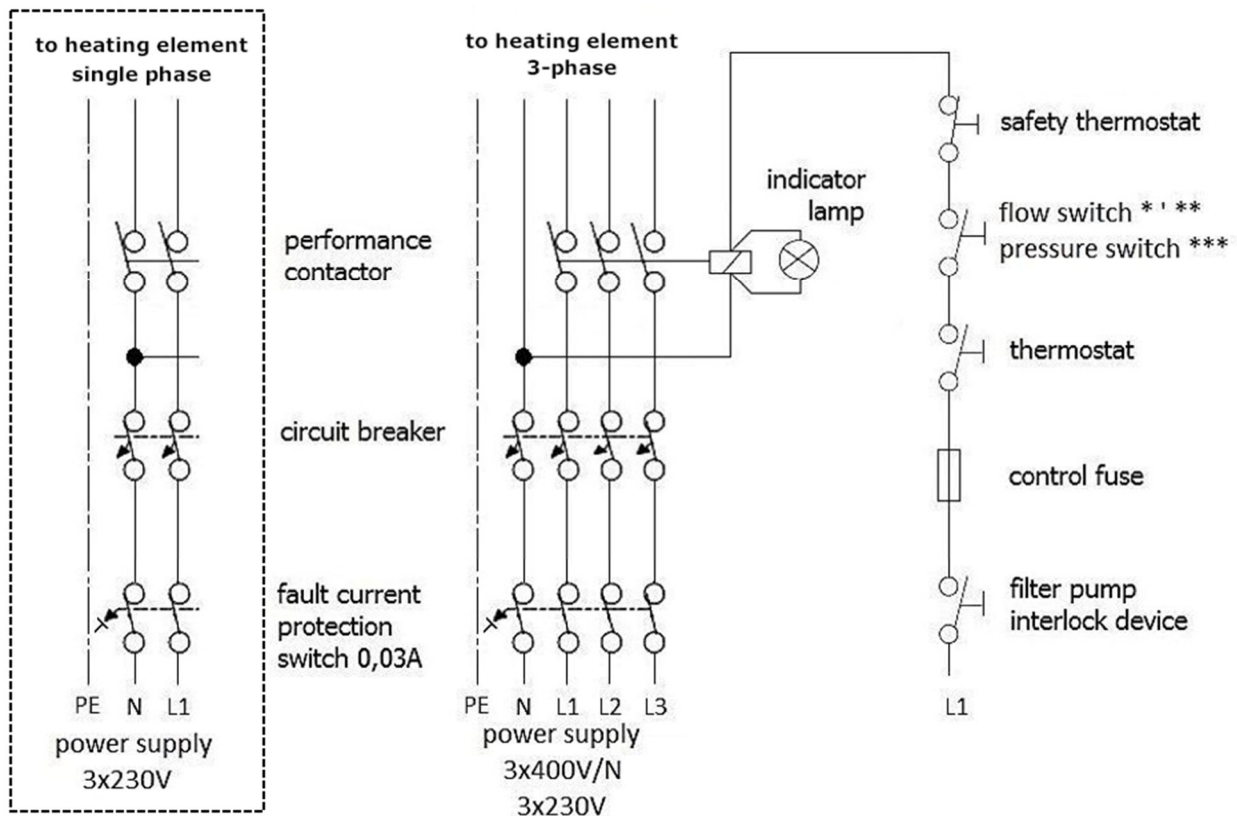
**10. Minimal Quantity of flow:**

With flow control 2800 l/h \* or 3000 l/h \*\* With pressure switch at 4000 l/h \*\*\*

**11. Safety Instructions:**

- 11.1 Before starting the Electric Heat Exchanger install an FI – safety switch (0,03 A) and a circuit breaker into the power supply.
- 11.2 The electric heat exchanger must be connected to the ground wire.
- 11.3 All metal parts are to be included in the potential equalization.
- 11.4 The device needs to be connected to the hard wire.
- 11.5 For the electrical connection, it is necessary to use a H07 RNF cable.
- 11.6 While cross sectioning the cable, please consider VDE 100.
- 11.7 The control circuit should carry maximal 1 A alternating current. The control box needs to be set for that particular maximum capacity.
- 11.8 It is very important to lock the operating protection for the heating element through the filter pump.

**12. Circuit Diagram:**





connection for 3x400V (3-phase current)

connection for 3x230V (3-phase current)

connection to max. 6kW for 1x230V alternating current

Diagram 1

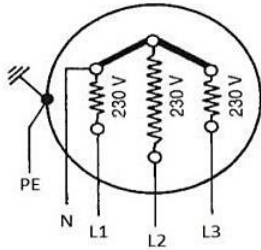


Diagramm 2

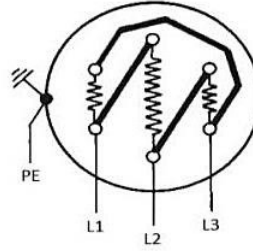
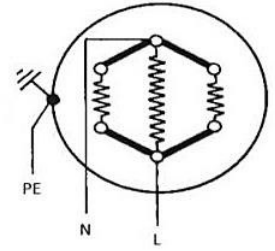
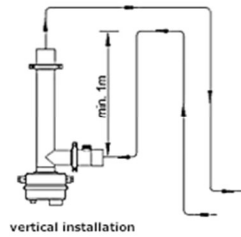
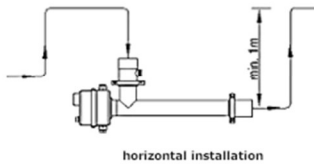


Diagram 3

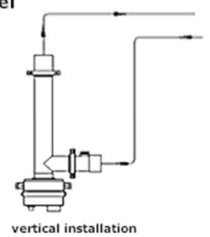
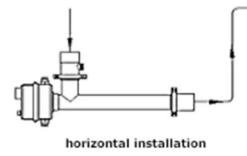


### 13. Installation Instruction Concept:

installation above the water level



installation below the water level



### 14. Important general note:

**It is essential that the Electric Heat Exchanger is installed in an area with adequate floor drainage.** If heat exchangers, filters and similar devices are damaged, water may escape uncontrollably. Cellars and similar areas may quickly become flooded and suffer material damage!

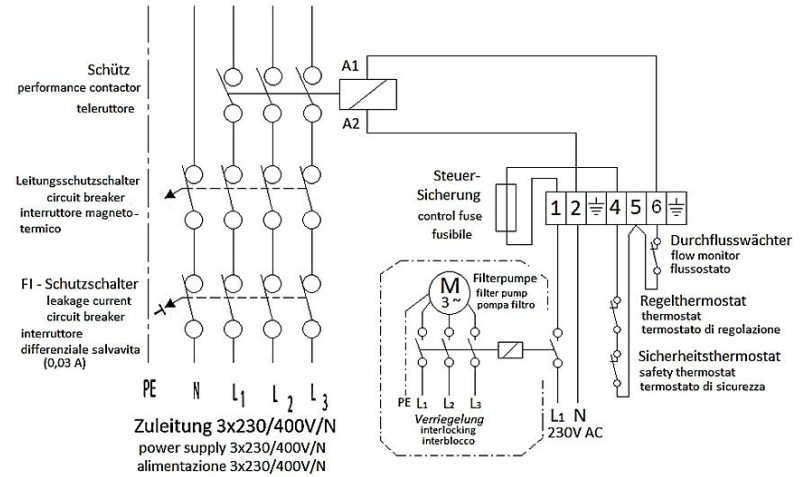
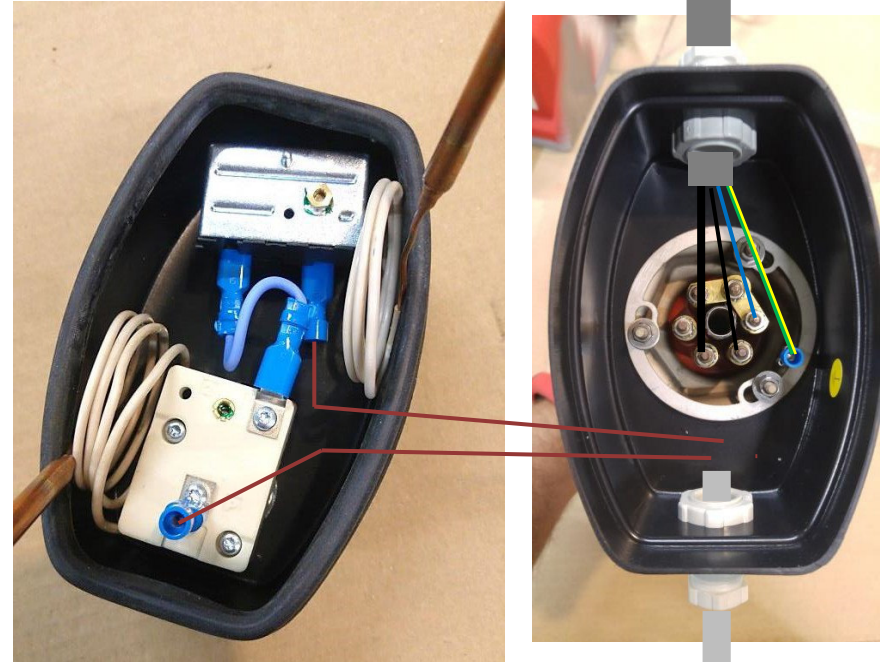
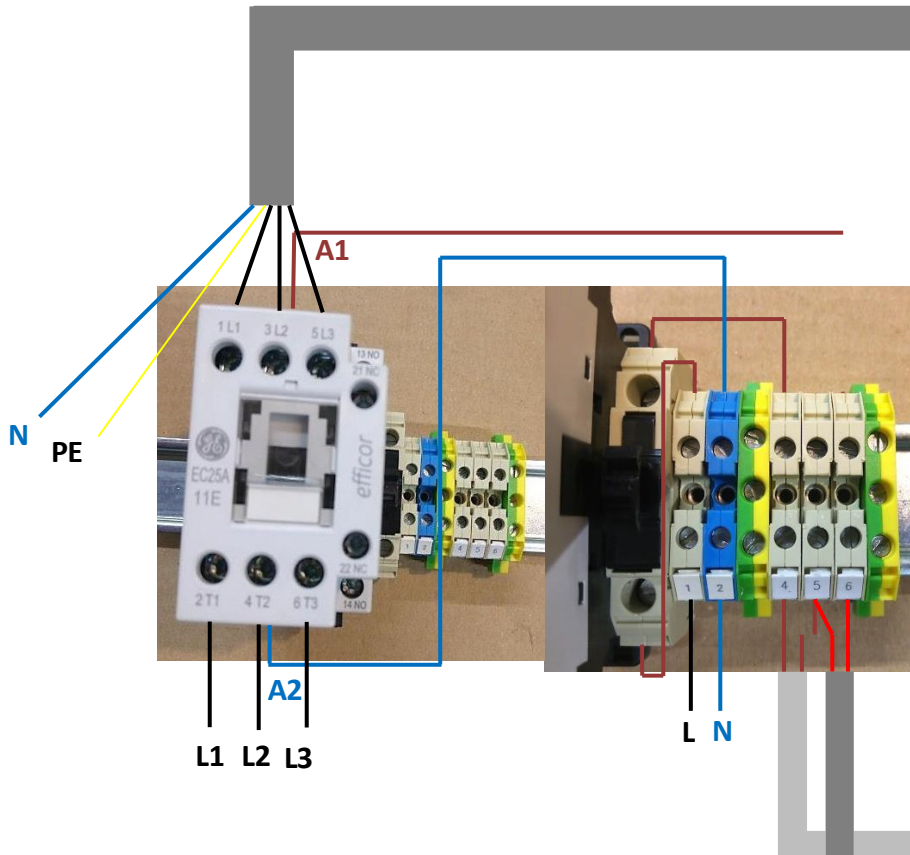
### 15. Please save these Installation and Assembly Instructions and include them in the construction file. Thank you!

12.07.2022 max daprà KG-daprà andreas&Co. Via Graf 2, I-39050 Fiè allo Sciliar

**technical changes reserved**

- \*) the model D-EWT C / Evo / Ti
- \*\*) the model D-EWT Neo
- \*\*) the model D-EWT E

# Correct wiring of an electric heat exchanger



Wrong wiring of an electric heat exchanger

